

# PST-SERIES

# SUPER-TWEETER

## PST-535 (HIGH FREQUENCY SUPER TWEETER)

### GENERAL SPECIFICATIONS

|                             |  |              |
|-----------------------------|--|--------------|
| Nominal Impedance           | : 8  | ohm          |
| Frequency Range             | : 6K~20K   | Hz           |
| Average Sensitivity (1w/1m) | : 112  | dB           |
| Power Capacity              | : 75~300   | Watts        |
| Voice Coil Diameter         | : 44.4   | mm (1.75 in) |
| Disersion HxV               | : 40°  |              |
| Polar Response-6dB          | : 10K  | Hz 40°H      |
| Flux Density                | : 1.6  | T            |
| Magnet                      | : Strontium Ferrite                              |              |
| Diaphragm                   | : Titanium                                       |              |
| Voice Coil Materials        | : Edge Wound Aluminium Wire                      |              |
| Basket                      | : Cast Aluminium                                 |              |
| Net Weight                  | : 2.21   | Kg (4.86Lb)  |
| Dimension(H X W X D)        | : 170mm X 130mm X 120mm<br>6.7in X 5.1in X 4.7in |              |

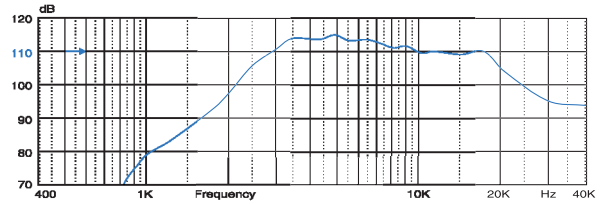
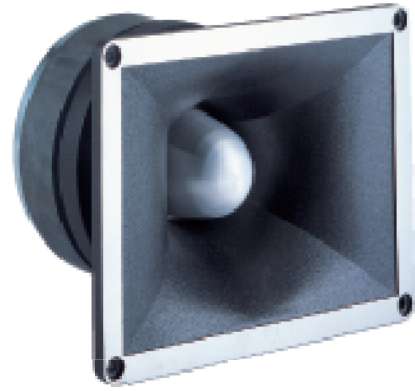
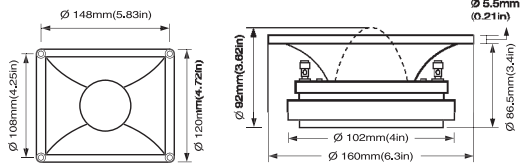

## PST-545 (HIGH FREQUENCY SUPER TWEETER)

### GENERAL SPECIFICATIONS

|                             |  |              |
|-----------------------------|--|--------------|
| Nominal Impedance           | : 8  | ohm          |
| Frequency Range             | : 6K~20K   | Hz           |
| Average Sensitivity (1w/1m) | : 112  | dB           |
| Power Capacity              | : 75~300   | Watts        |
| Voice Coil Diameter         | : 44.4   | mm (1.75 in) |
| Disersion HxV               | : 40°  |              |
| Polar Response-6dB          | : 10K  | Hz 40°H      |
| Flux Density                | : 1.6  | T            |
| Magnet                      | : Strontium Ferrite                              |              |
| Diaphragm                   | : Titanium                                       |              |
| Voice Coil Materials        | : Edge Wound Aluminium Wire                      |              |
| Basket                      | : Cast Aluminium                                 |              |
| Net Weight                  | : 2.13   | Kg (4.68Lb)  |
| Dimension(H X W X D)        | : 130mm X 130mm X 100mm<br>5.1in X 5.1in X 3.9in |              |

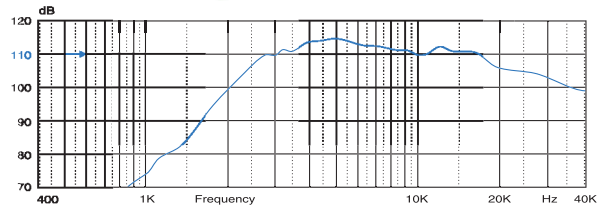
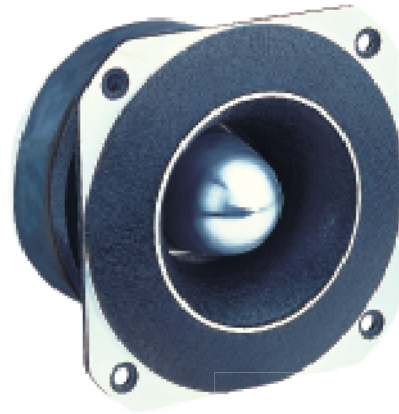
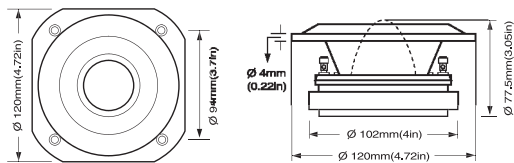

## PST-555 (HIGH FREQUENCY SUPER TWEETER)

### GENERAL SPECIFICATIONS

|                             |   |              |
|-----------------------------|---|--------------|
| Nominal Impedance           | : 8   | ohm          |
| Frequency Range             | : 6K~20K  | Hz           |
| Average Sensitivity (1w/1m) | : 110   | dB           |
| Power Capacity              | : 40~250  | Watts        |
| Voice Coil Diameter         | : 37.5  | mm (1.47 in) |
| Disersion HxV               | : 40°   |              |
| Polar Response-6dB          | : 10K   | Hz 40°H      |
| Flux Density                | : 1.6   | T            |
| Magnet                      | : Strontium Ferrite                             |              |
| Diaphragm                   | : Titanium                                      |              |
| Voice Coil Materials        | : Edge Wound Aluminium Wire                     |              |
| Basket                      | : Cast Aluminium                                |              |
| Net Weight                  | : 1.72  | Kg (3.78Lb)  |
| Dimension(H X W X D)        | : 115mm X 115mm X 95mm<br>4.5in X 4.5in X 3.7in |              |

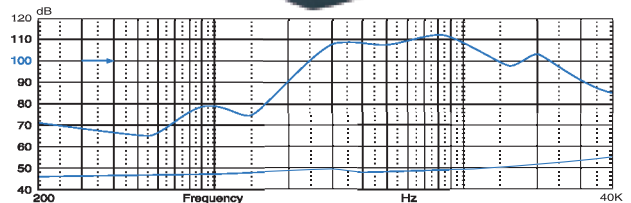
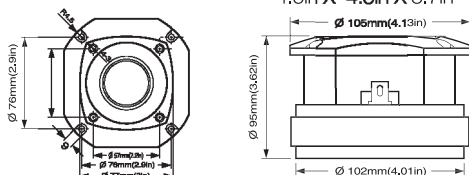

# PST-SERIES

# SUPER-TWEETER

## PST-777 (HIGH FREQUENCY SUPER TWEETER)

### GENERAL SPECIFICATIONS

|                             |  |       |           |
|-----------------------------|--|-------|-----------|
| Nominal Impedance           | : 8  | ohm   |           |
| D.C Resistance              | : 6  | ohm   |           |
| Frequency Range             | : 3K~15K   | Hz    |           |
| Average Sensitivity (1w/1m) | : 114  | dB    |           |
| Power Capacity              | : 75~300   | Watts |           |
| Voice Coil Diameter         | : 72.2   | mm    | (2.84 in) |
| Magnet Weight               | : 1.3  | Kg    | (45 oz)   |
| Polar Response-6dB          | : 15K  | Hz    | 30°H      |
| Magnet                      | : Strontium Ferrite                              |       |           |
| Diaphragm                   | : Titanium                                       |       |           |
| Voice Coil Materials        | : Edge Wound Aluminium Wire                      |       |           |
| Basket                      | : Cast Aluminium                                 |       |           |
| Net Weight                  | : 5.4  | Kg    | (11.88Lb) |
| Dimension(H X W X D)        | : 220mm X 190mm X 120mm<br>8.6in X 7.4in X 4.7in |       |           |

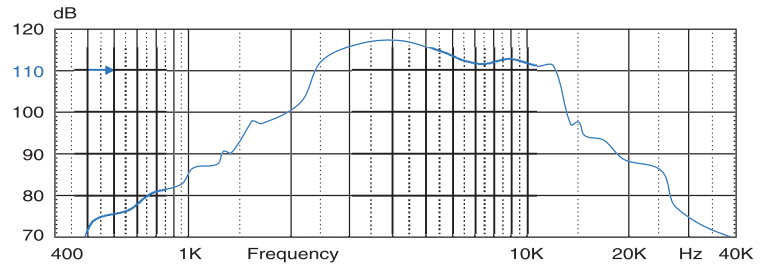
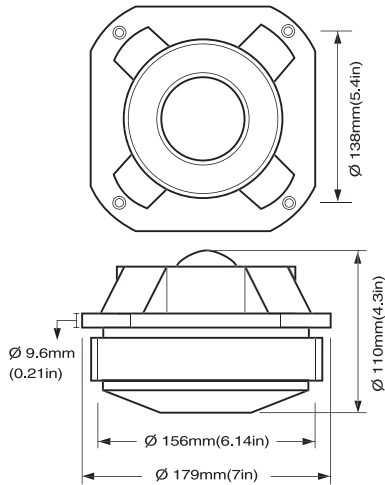
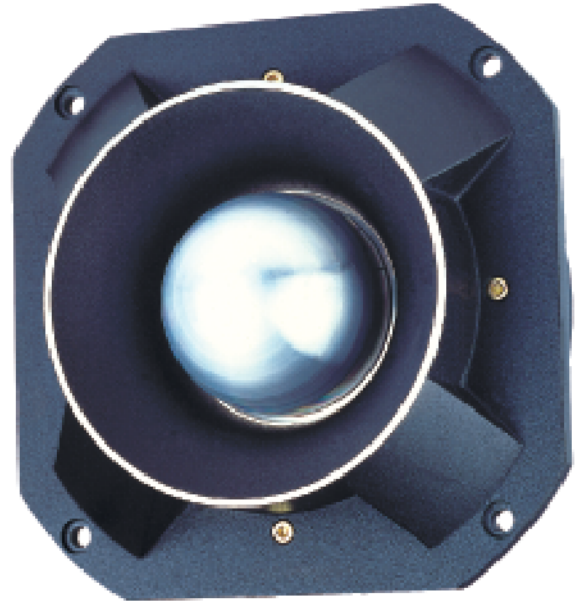

## PST-787 (HIGH FREQUENCY SUPER TWEETER)

### GENERAL SPECIFICATIONS

|                             |  |       |           |
|-----------------------------|--|-------|-----------|
| Nominal Impedance           | : 8  | ohm   |           |
| D.C Resistance              | : 6  | ohm   |           |
| Frequency Range             | : 3K~15K   | Hz    |           |
| Average Sensitivity (1w/1m) | : 114  | dB    |           |
| Power Capacity              | : 75~300   | Watts |           |
| Voice Coil Diameter         | : 72.2   | mm    | (2.84 in) |
| Magnet Weight               | : 1.3  | Kg    | (45 oz)   |
| Disersion HxV               | : 40°  |       |           |
| Polar Response-6dB          | : 15K  | Hz    | 30°H      |
| Magnet                      | : Strontium Ferrite                              |       |           |
| Diaphragm                   | : Titanium                                       |       |           |
| Voice Coil Materials        | : Edge Wound Aluminium Wire                      |       |           |
| Basket                      | : Cast Aluminium                                 |       |           |
| Net Weight                  | : 5.61   | Kg    | (12.34Lb) |
| Dimension(H X W X D)        | : 190mm X 190mm X 140mm<br>7.4in X 7.4in X 5.5in |       |           |

